



Technical Data **Active Antenna Splitter „EASY Split“**
Part No. **A-016**
Manufacturer: **Weatherdock AG, Am Weichselgarten 7, 91058 Erlangen, Germany**

Topology: Frequency selective, passive Power Divider with 4 Ports and active Saffey Switches

Ports: 1) VHF Antenna IN/OUT, 50 Ohm, SO239
 2) VHF Radio IN/OUT, 50 Ohm, SO239
 3) AIS Receiver OUT, 50 Ohm, BNC
 4) FM Radio OUT, 50 Ohm, Chinch

Port Coupling Factors:

1 – 2	(VHF-Antenna – VHF-Radio):	145 – 165 MHz
	VHF Radio receiving:	< 3.8dB
	VHF Radio ON AIR:	< 0.8dB
1 – 3	(VHF-Antenna – AIS-Receiver):	145 – 165 MHz
	VHF Radio receiving:	< 3.8dB
	VHF Radio ON AIR:	> 30dB (channel switched off)
1 – 4	(VHF-Antenna – FM Radio):	80 – 108 MHz
	VHF Radio receiving:	< 3dB
	VHF Radio ON AIR:	> 40dB (channel switched off)
2 – 3	(VHF-Radio – AIS-Receiver):	145 – 165 MHz
	VHF Radio receiving:	> 20dB
	VHF Radio ON AIR:	> 30dB (channel switched off)

Power Handling: Maximum Transmit Power of VHF Radio: 30W
 Minimum Transmit Power of VHF Radio: 400mW

Attack Time (Saffey Switches): < 10msec, after Ramp up of Transmitter Power (lower limit: 400mW)

Power Supply: +9 to + 28V @ < 130mA

Fuse: Built-In Fuse
 variant 1: 500mA, slow blow; fuse can be exchanged by opening the enclosure
 variant 2: 200mA, selfhealing; fuse not changeable

User Interface: Switch, Power ON/OFF (optional)
 LED indicator for Power ON: green
 LED indicator for VHF Radio ON AIR: red

Connector/Cable: RJ45 type jack, cable included

Pin 1:	not connected, white-orange	Pin 5:	Ground, white-blue
Pin 2:	Ground, orange	Pin 6:	not connected, green
Pin 3:	not connected, white-green	Pin 7:	not connected, white-brown
Pin 4:	Ground, blue	Pin 8:	+9 to + 28V DC IN, brown

Mechanics:
Size (overall): 140 x 140 x 36 mm

Weight: approx. 430g

Miscellaneous: PCB conformal coated



Approval:

- CE, IEC/EN60945 :2002
- FCC CFR 47, part 15, sections 15.107 and 15.109 (Class B), (USA)
- RSS-182, Issue 4, Maritime Radio Transmitters and Receivers in the 156 to 162.5 MHz Band, (Canada)

Block Diagram

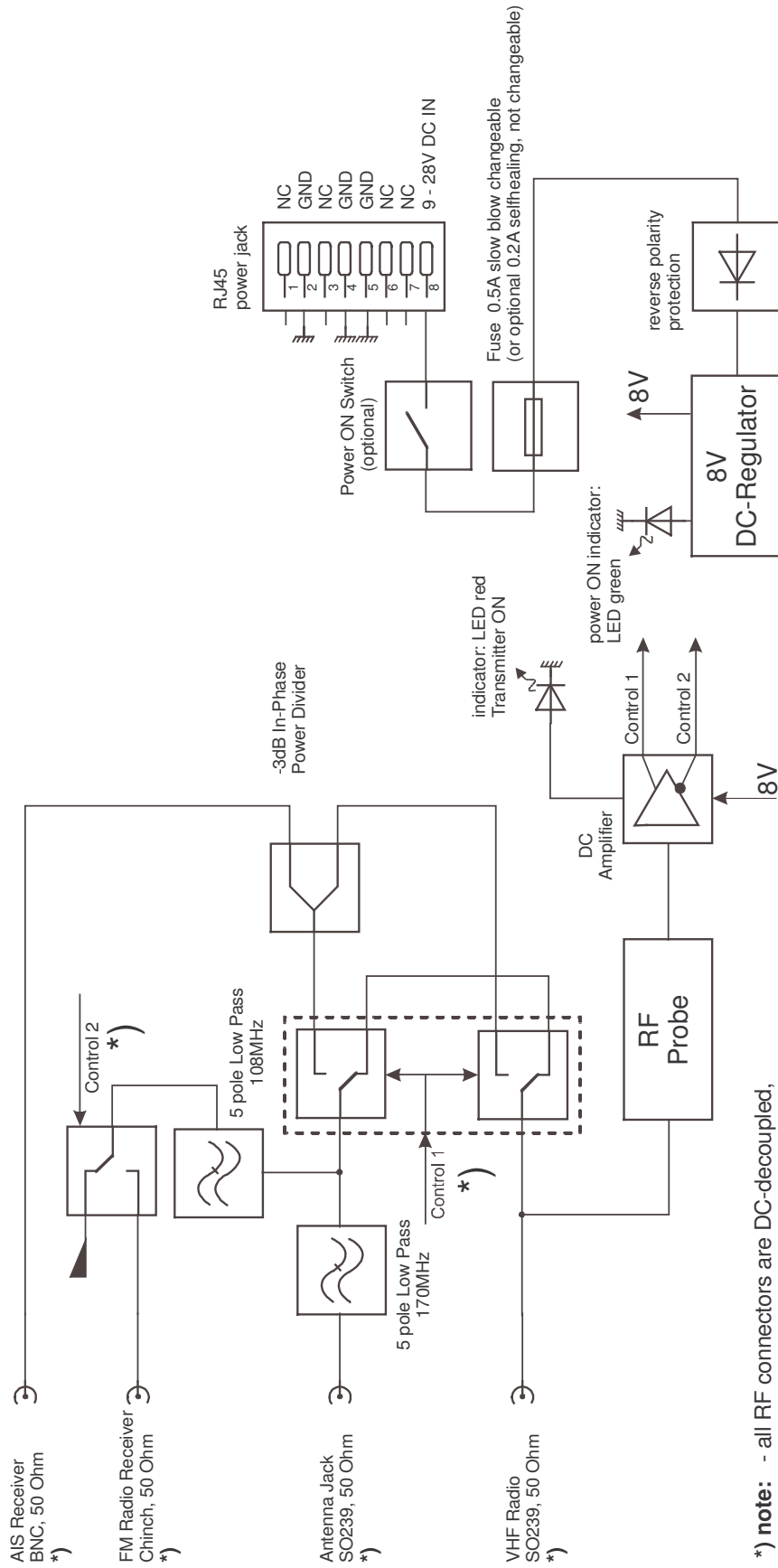

***) note:** - all RF connectors are DC-decoupled, ground terminals are DC-decoupled to power ground
 - switches position is shown for
 - circuit not DC powered or
 - VHF-transmitter active